

# I DISEGNI GEOMETRICI DI GIO PONTI

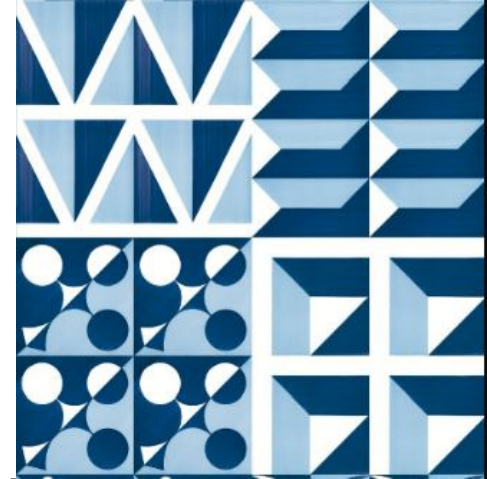

Create la vostra mattonella!

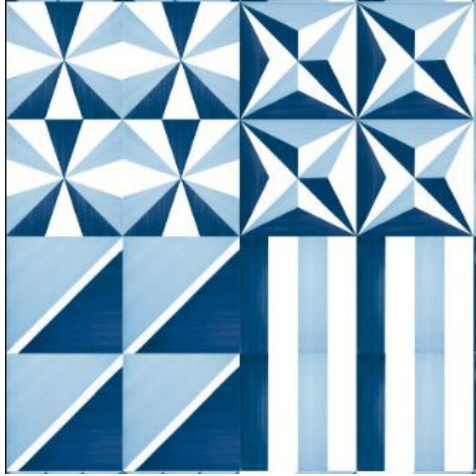

# Ma chi è GIÒ PONTI?

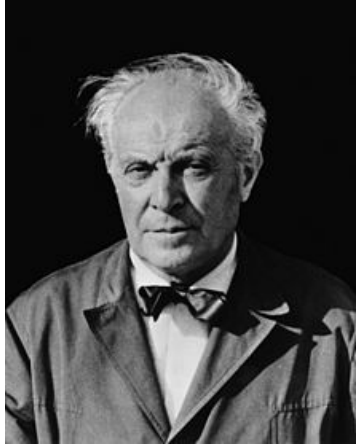

Giovanni (detto Giò) PONTI (Milano, 18 novembre 1891 – Milano, 16 settembre 1979) è stato un architetto, designer, saggista e accademico italiano che condusse una carriera unica, partecipando attivamente alla rinascita del design italiano del dopoguerra.

Ha progettato numerosi edifici tra cui il famoso GRATTACIELO PIRELLI a Milano. Ha disegnato le ceramiche per la Richard-Ginori e progettato numerose linee di arredamento.

Nel 1962, per il progetto dell'Hotel Parco dei Principi di Sorrento, disegna le decorazioni "bianche e blu oltremare" in ceramica, con 27 combinazioni di maioliche "matematiche e geometriche" 20cm x 20cm.



# COME PROGETTAVA LE CERAMICHE.....

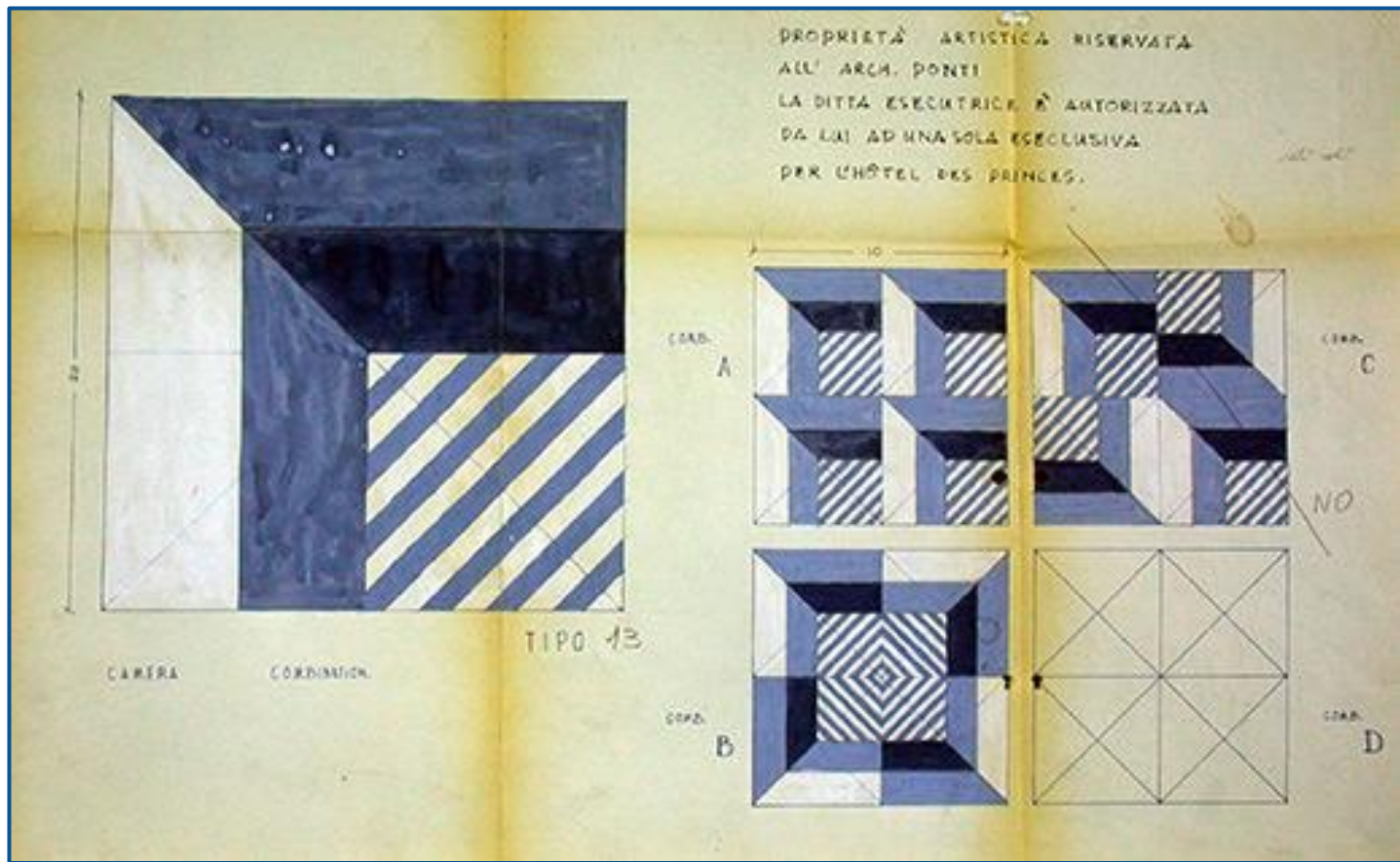

ESEMPIO

1



# COME PROGETTAVA LE CERAMICHE.....

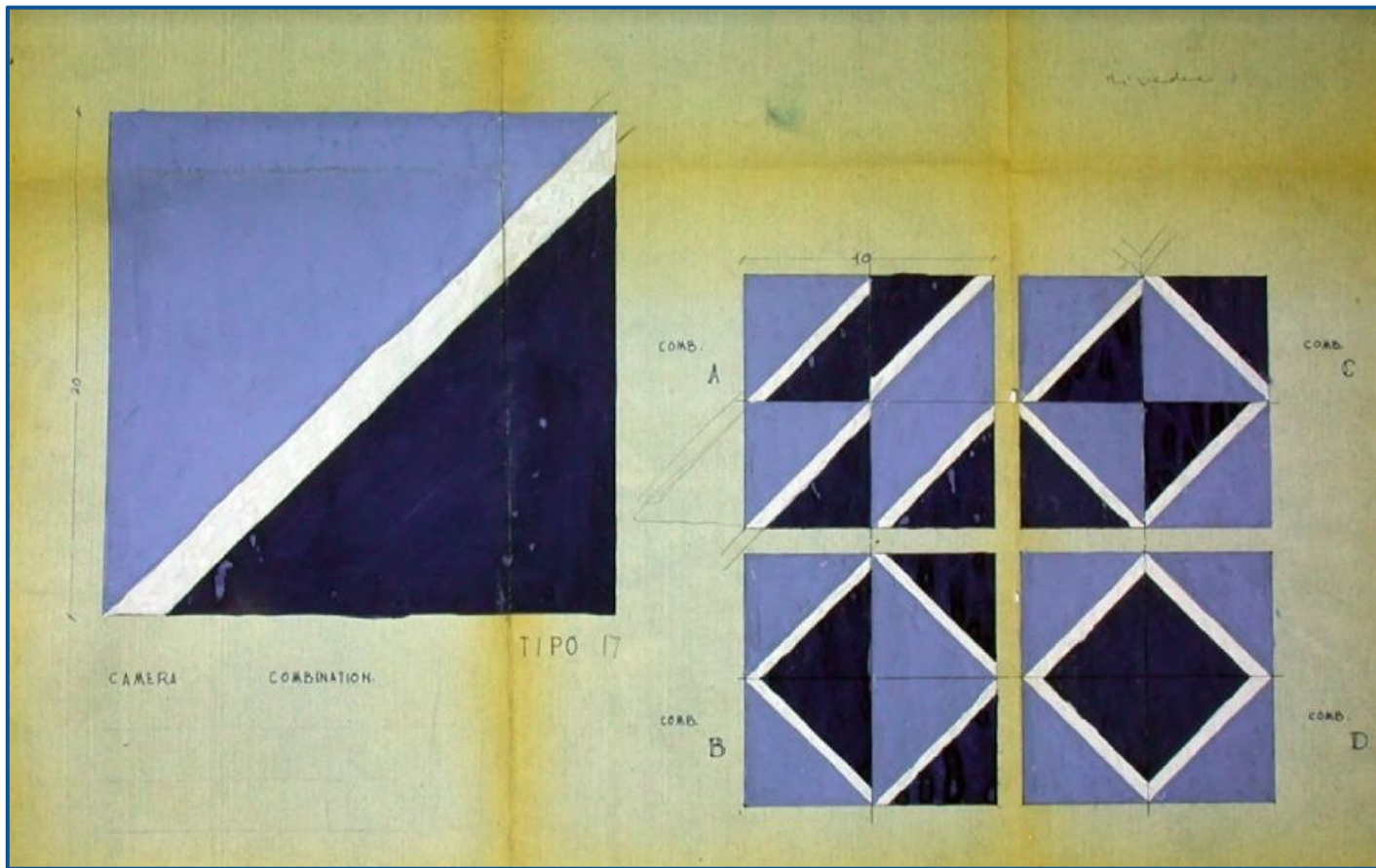

**ESEMPIO  
2**

# COME PROGETTAVA LE CERAMICHE.....

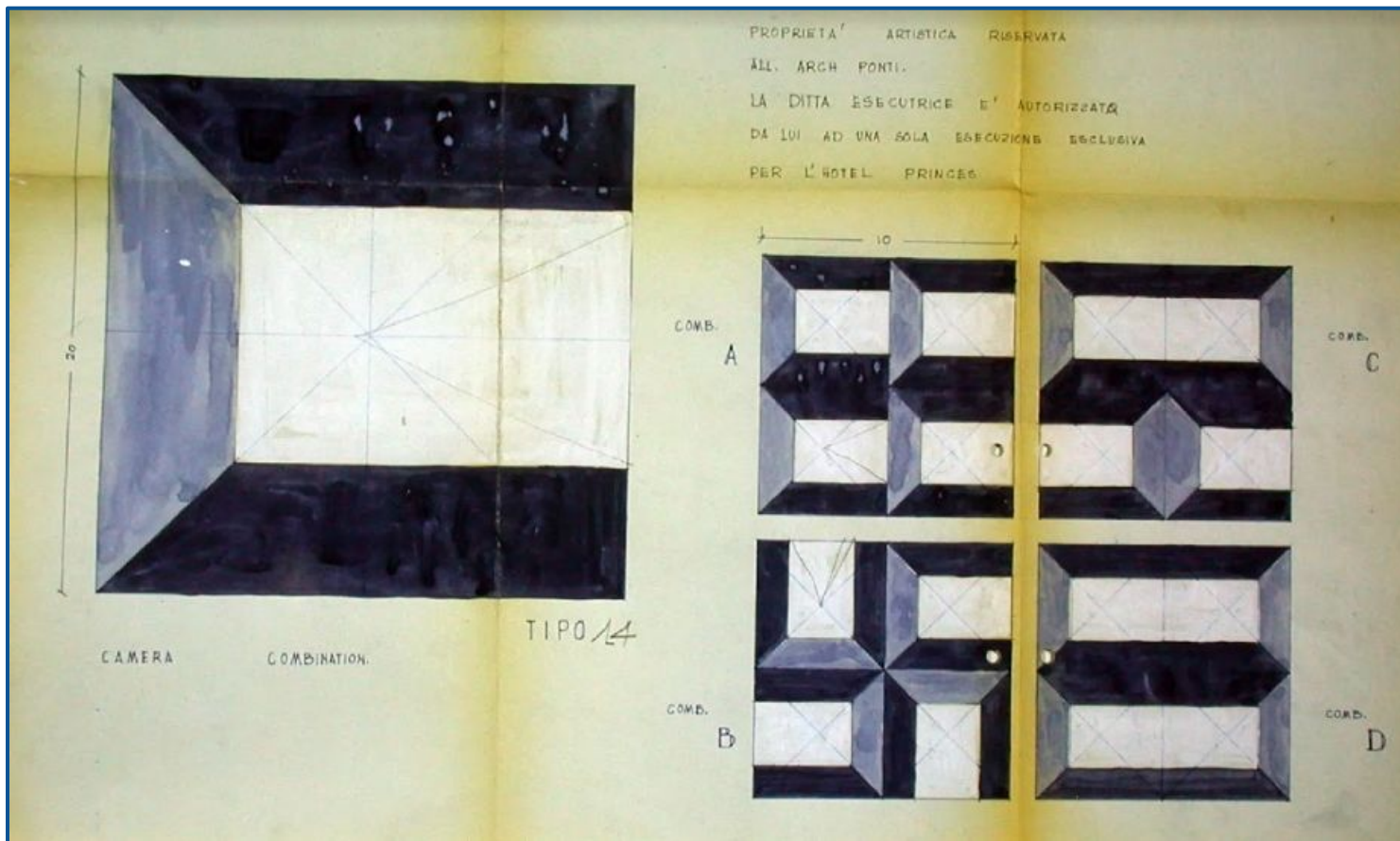

ESEMPIO  
3

# DAL DISEGNO ALLA MATTONELLA

# DISEGNO 1

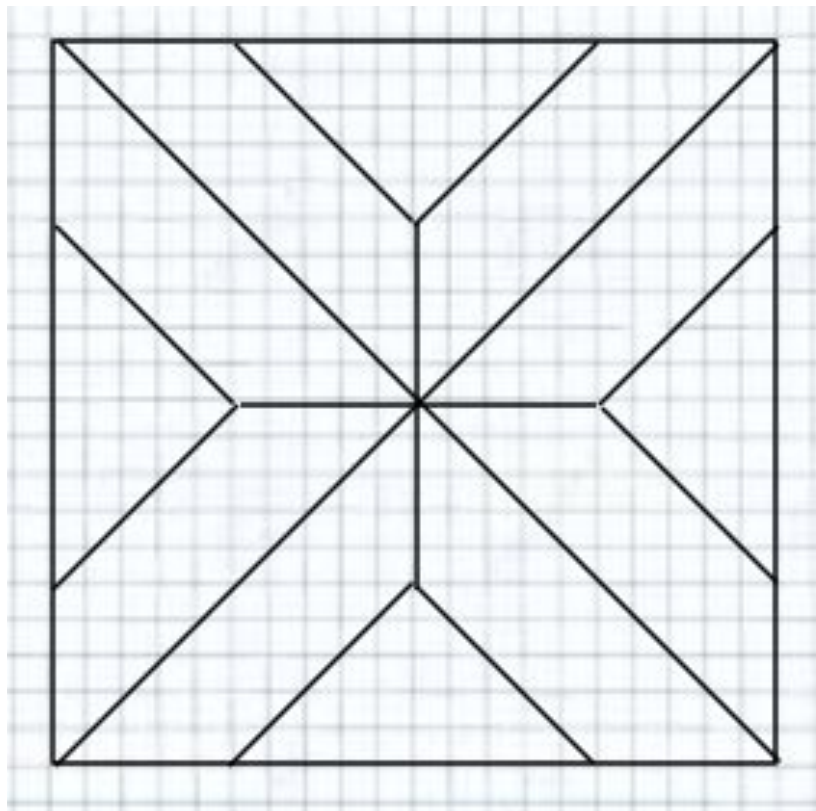

# COMPOSIZIONI

DISEGNO 1

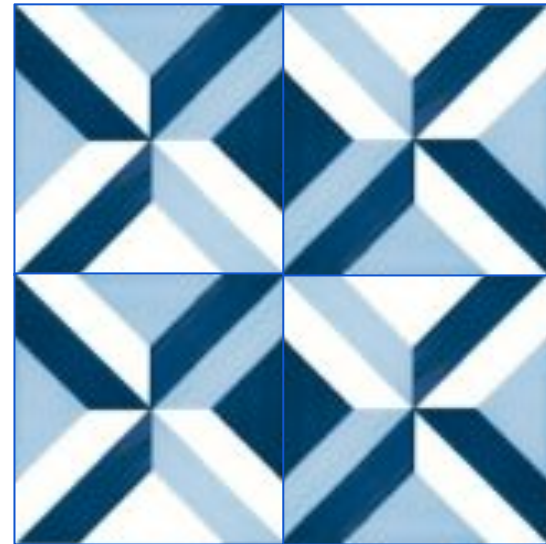
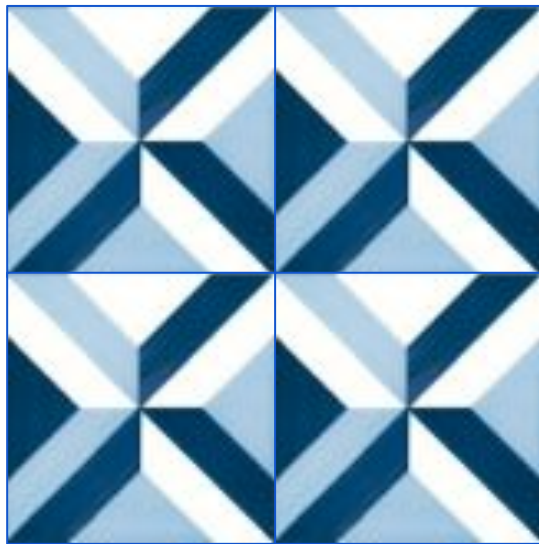
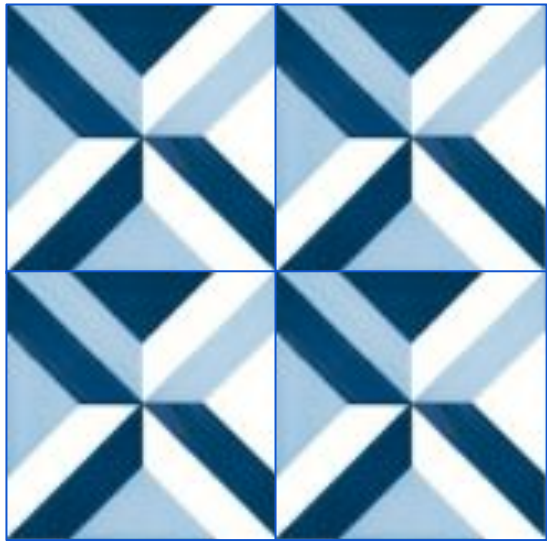



# DAL DISEGNO ALLA MATTONELLA

## DISEGNO 2

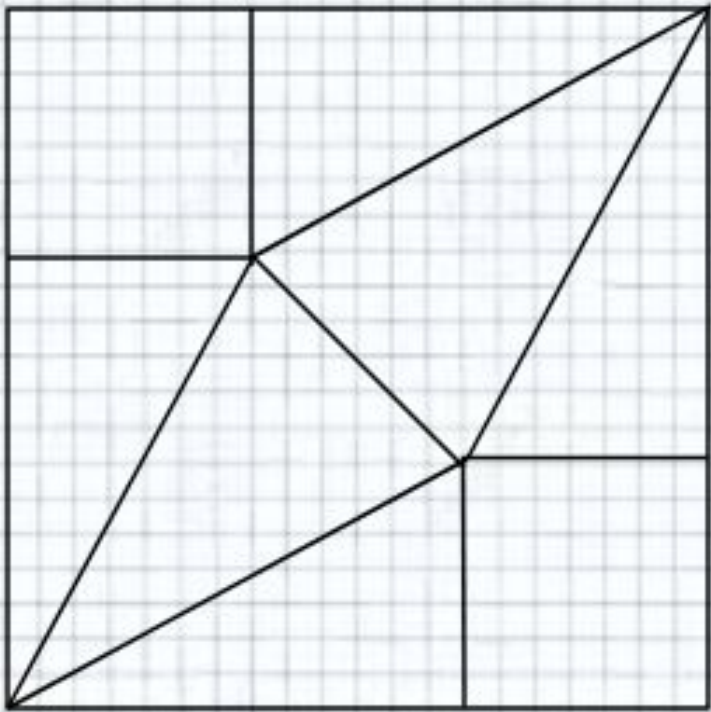



# COMPOSIZIONI

## DISEGNO 2

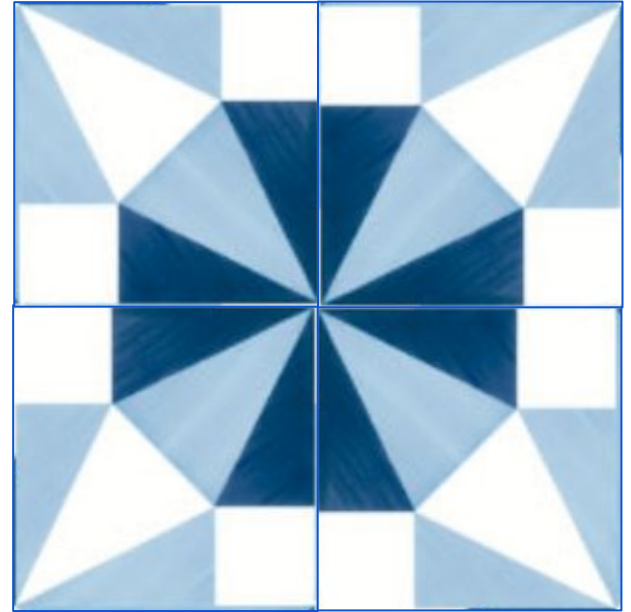
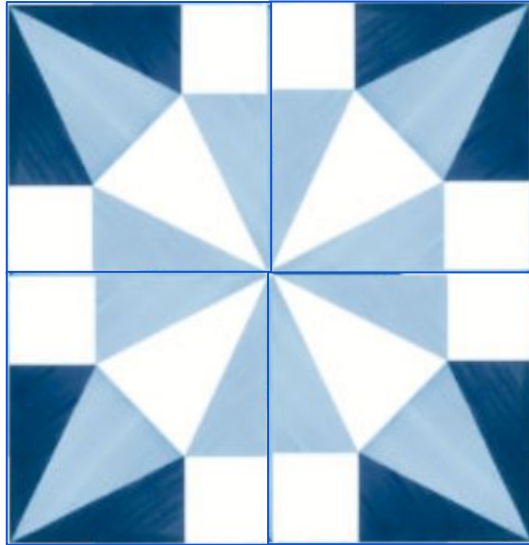
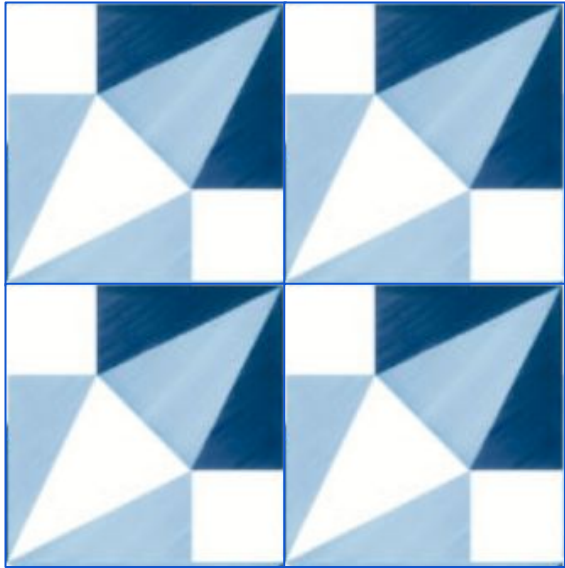

# DAL DISEGNO ALLA MATTONELLA

# DISEGNO 3

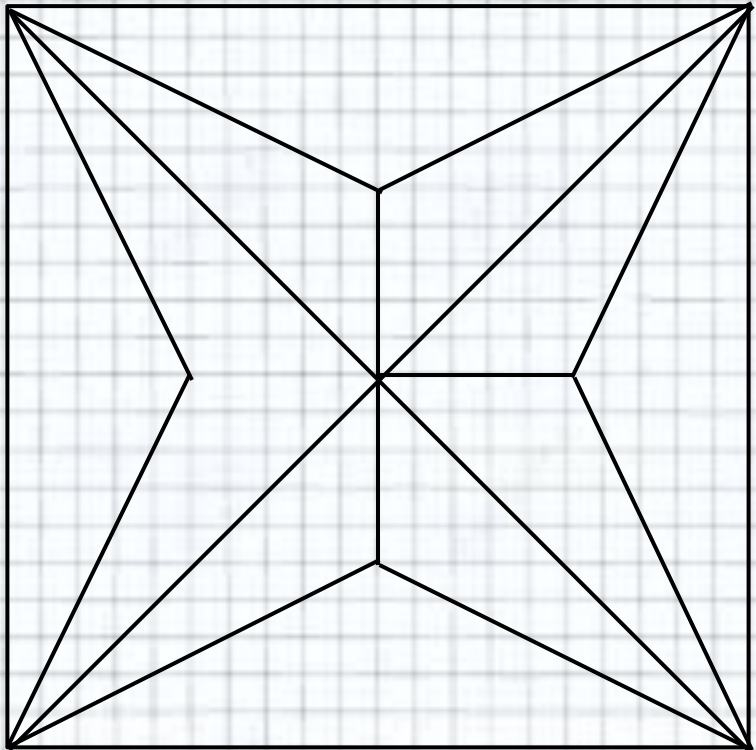

# COMPOSIZIONI

## DISEGNO 3

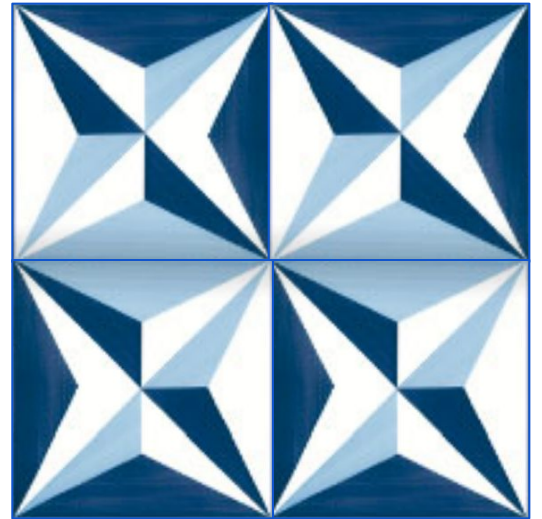
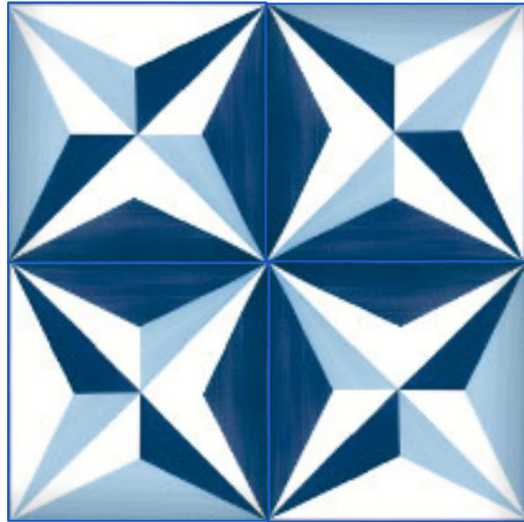

DAL DISEGNO ALLA MATTONELLA

DISEGNO 4

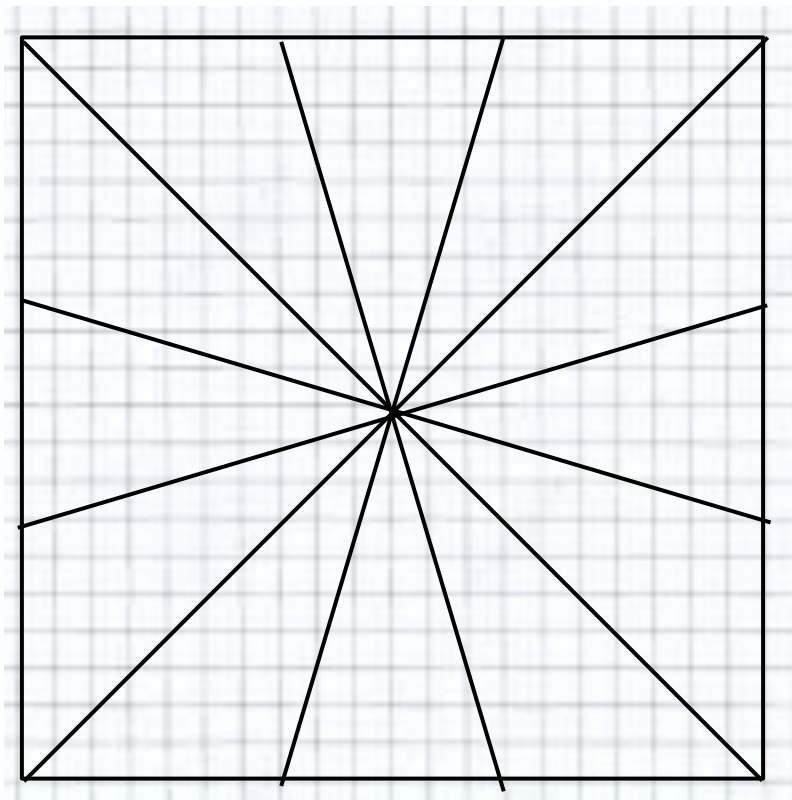



# COMPOSIZIONI

## DISEGNO 4

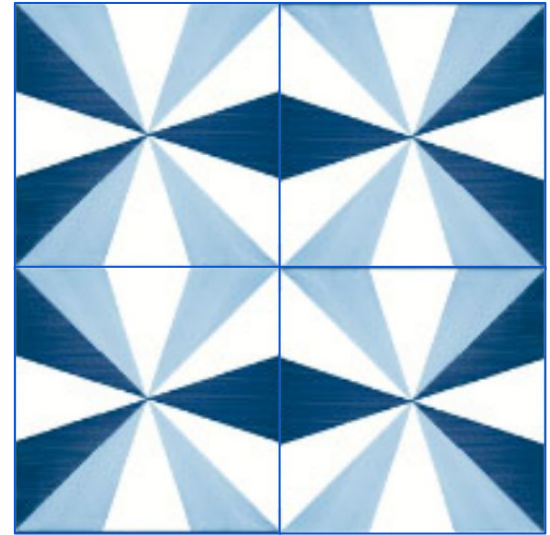
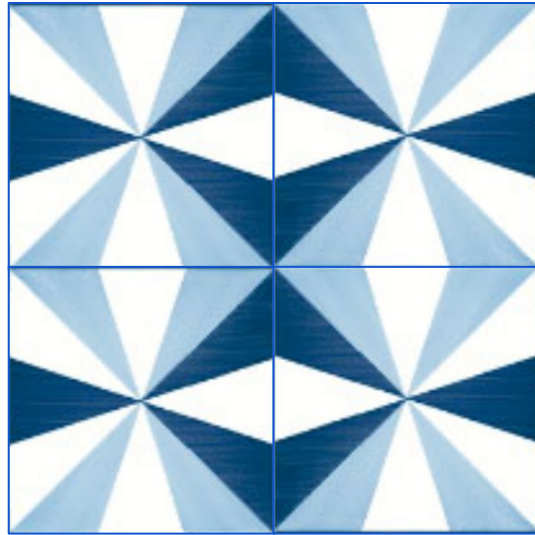
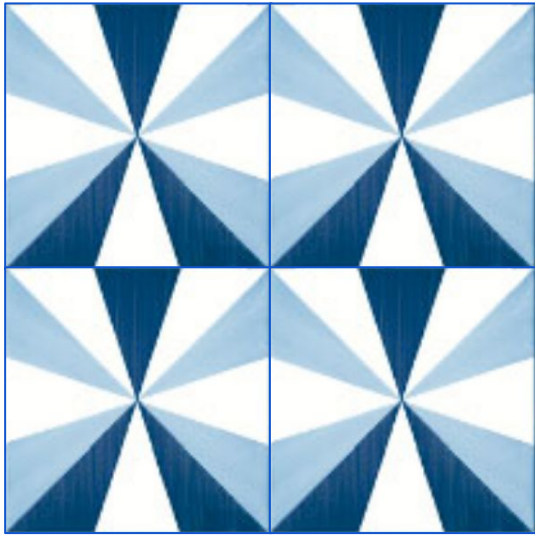

# DAL DISEGNO ALLA MATTONELLA

DISEGNO 5

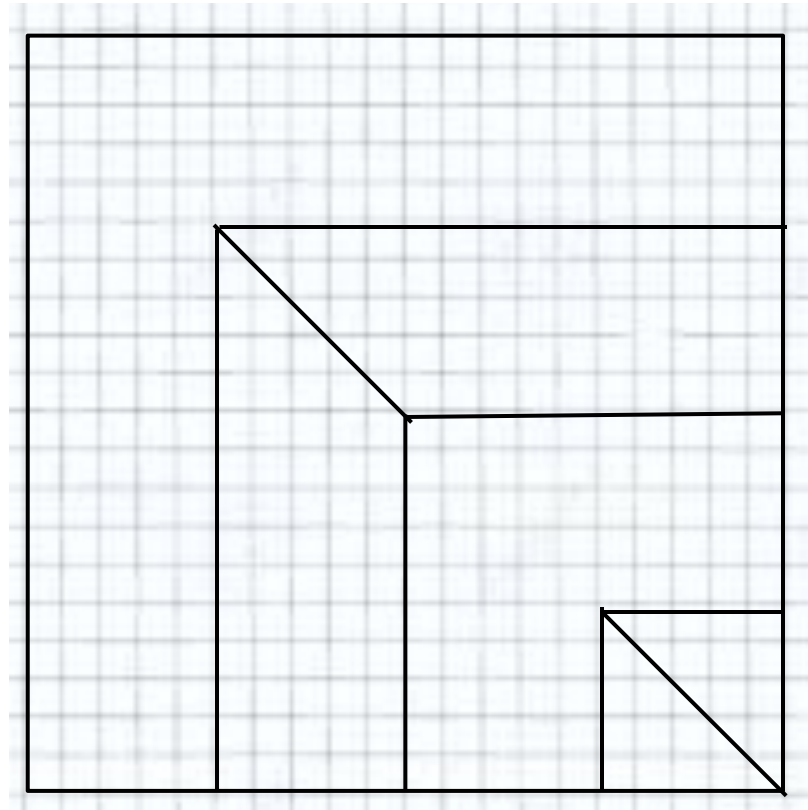

# COMPOSIZIONI

## DISEGNO 5

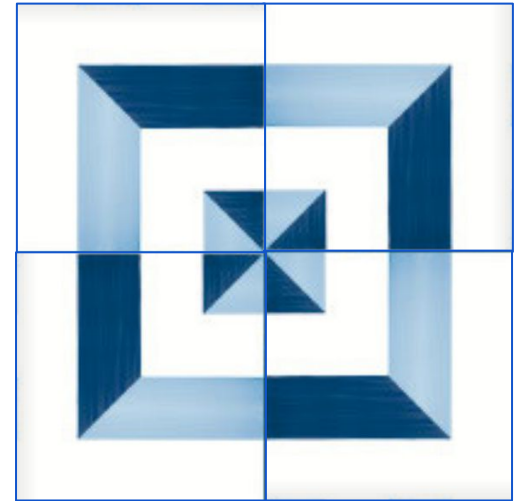
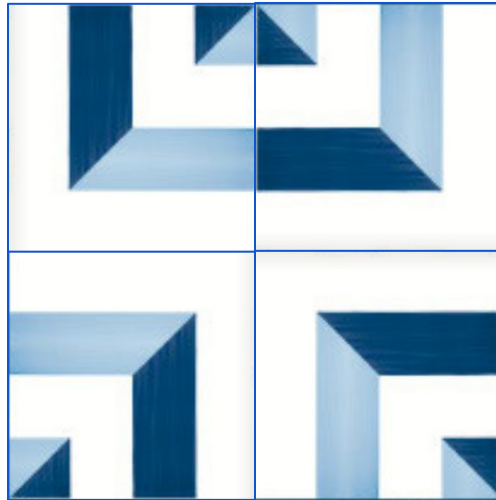
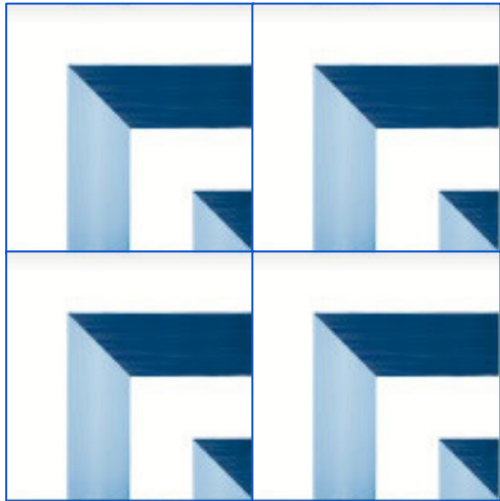

# DAL DISEGNO ALLA MATTONELLA

DISEGNO 6

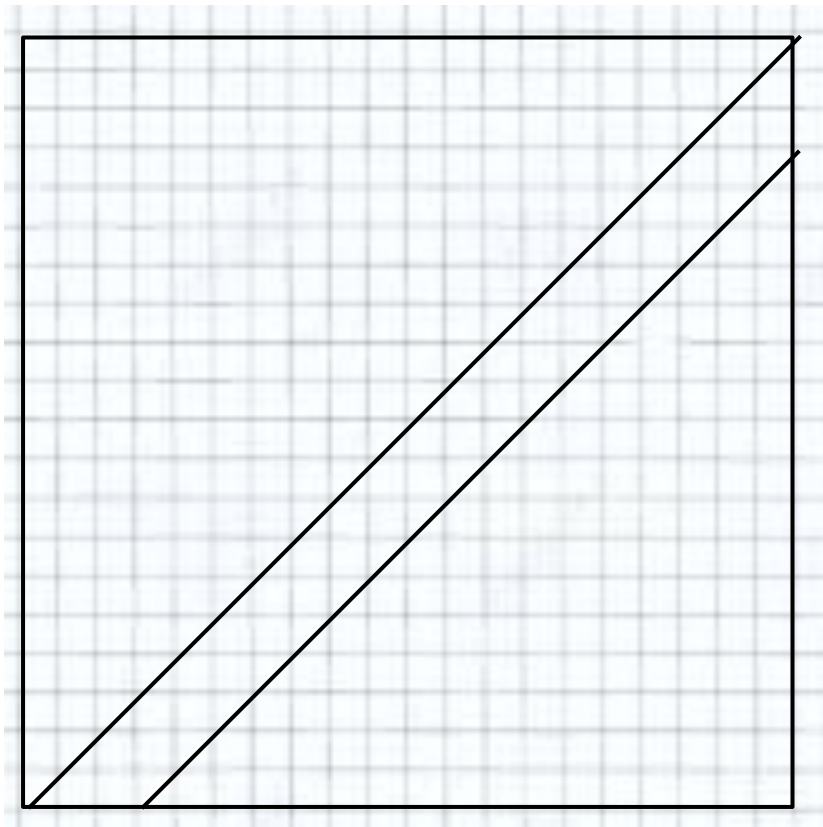



# COMPOSIZIONI

DISEGNO 6

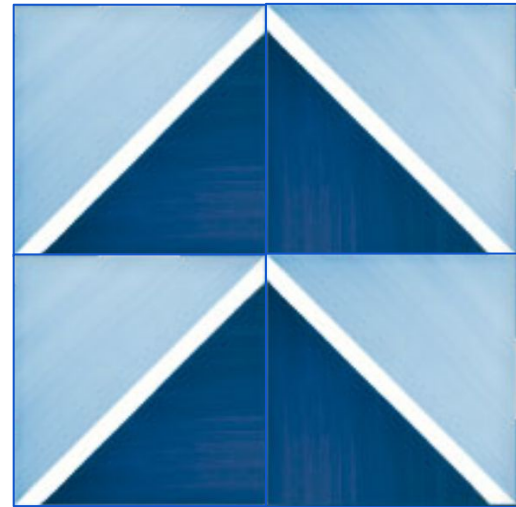
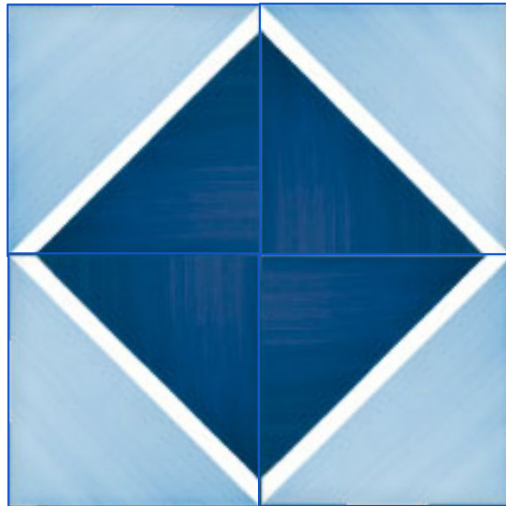
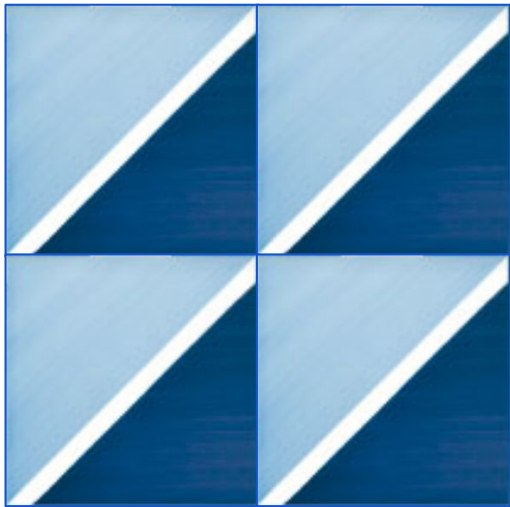

DAL DISEGNO ALLA MATTONELLA

DISEGNO 7

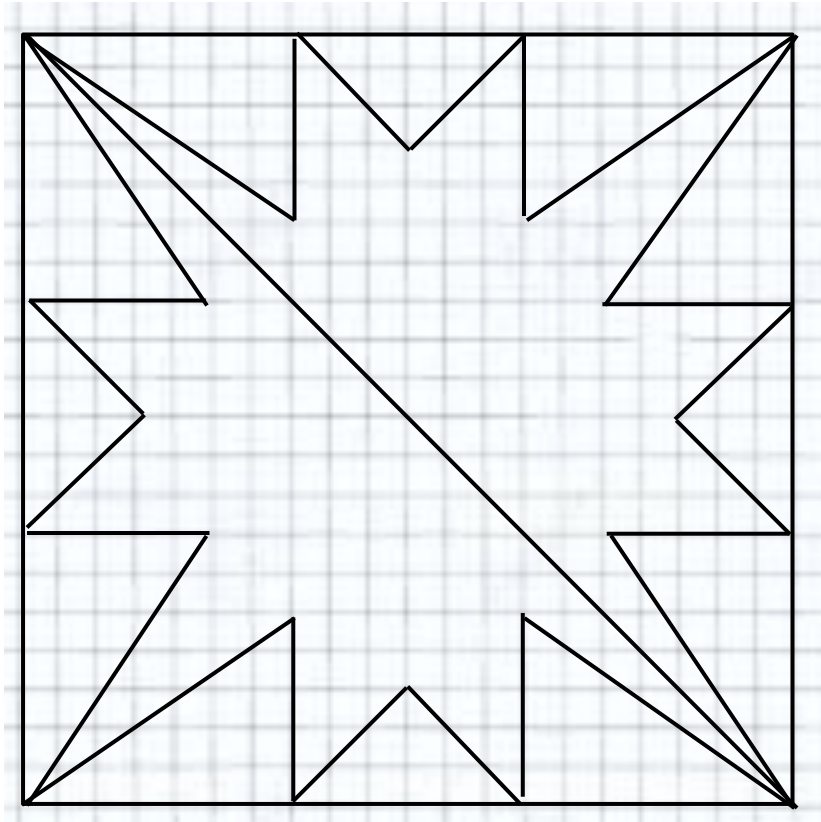

# COMPOSIZIONI

DISEGNO 7



# DAL DISEGNO ALLA MATTONELLA

DISEGNO 8

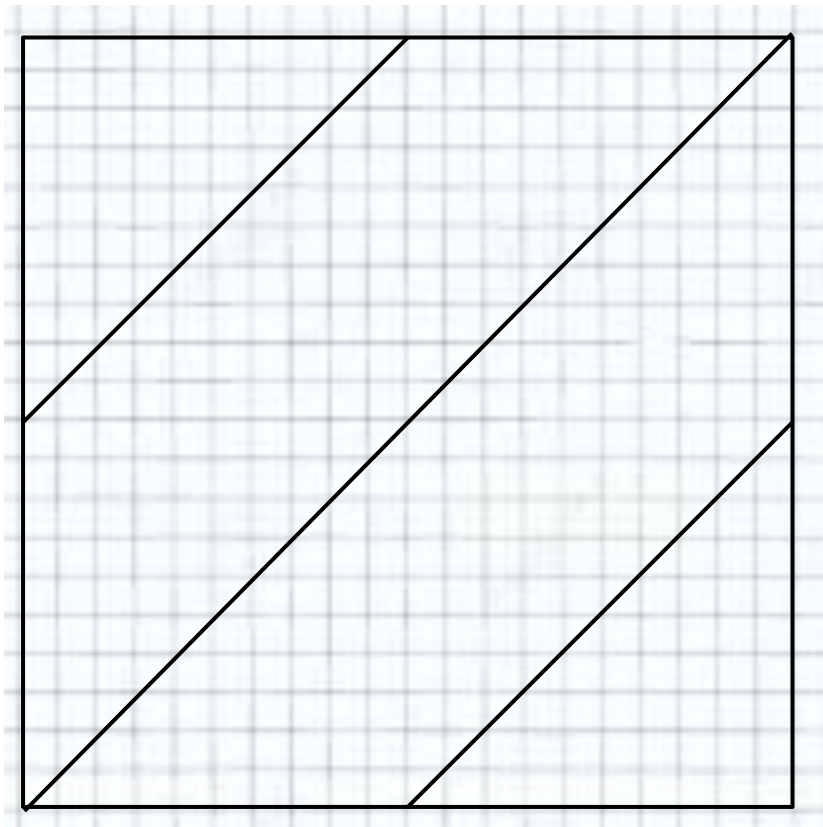



# COMPOSIZIONI

DISEGNO 8

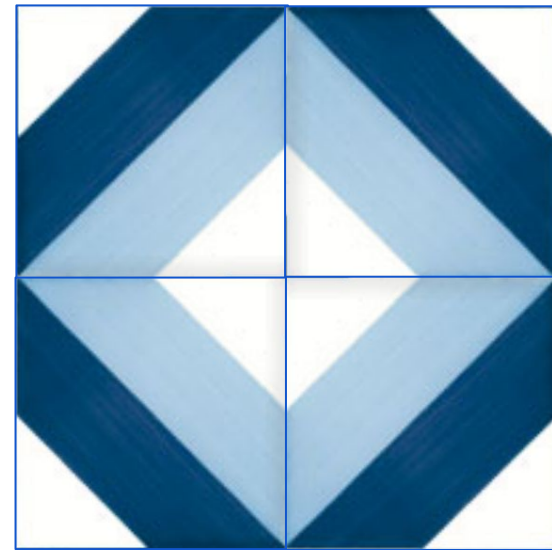
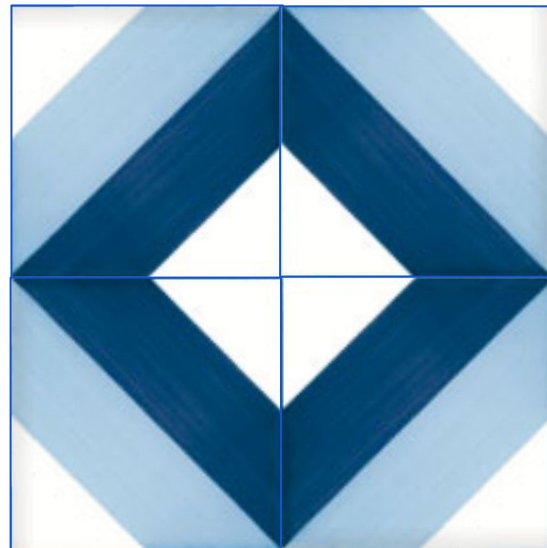
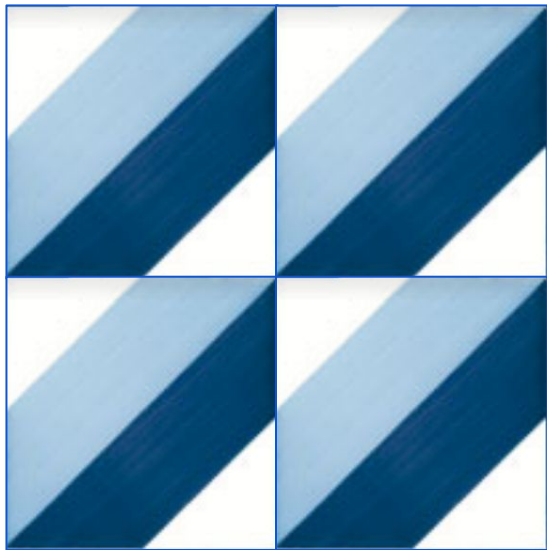

# DAL DISEGNO ALLA MATTONELLA

DISEGNO 9

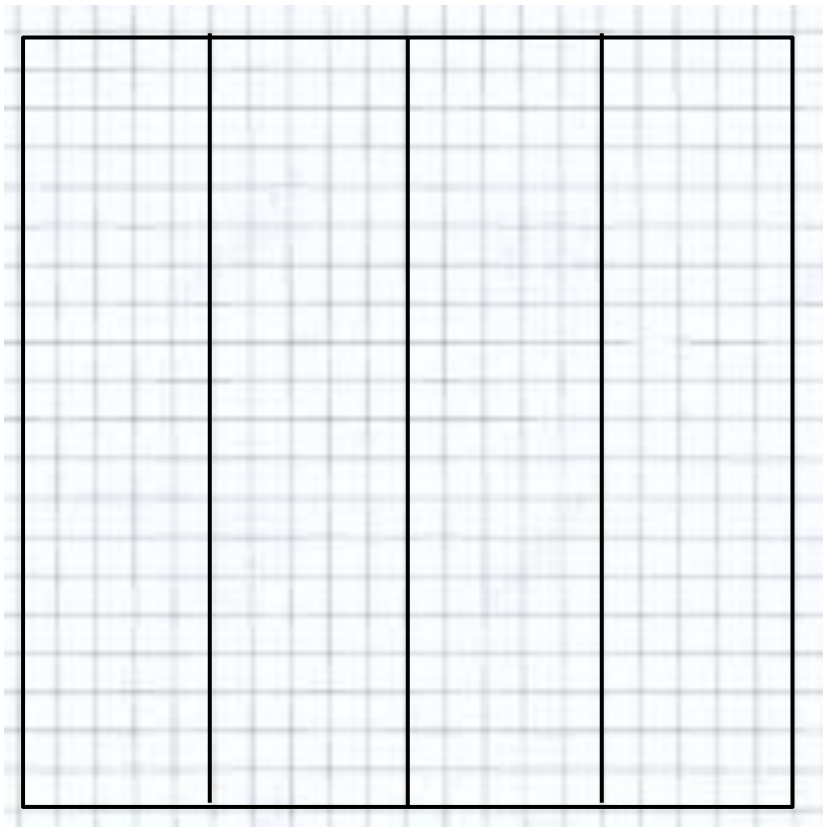

# COMPOSIZIONI

DISEGNO 9

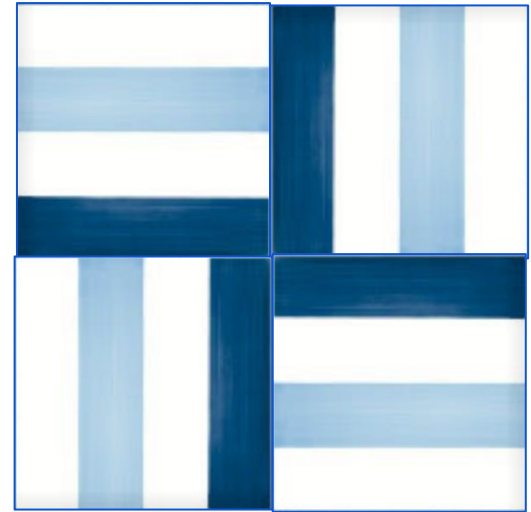
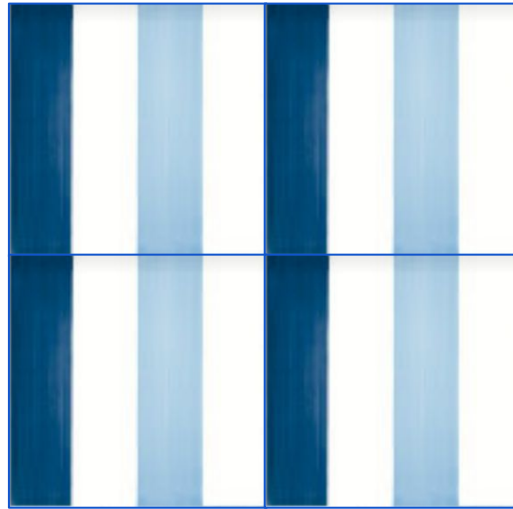
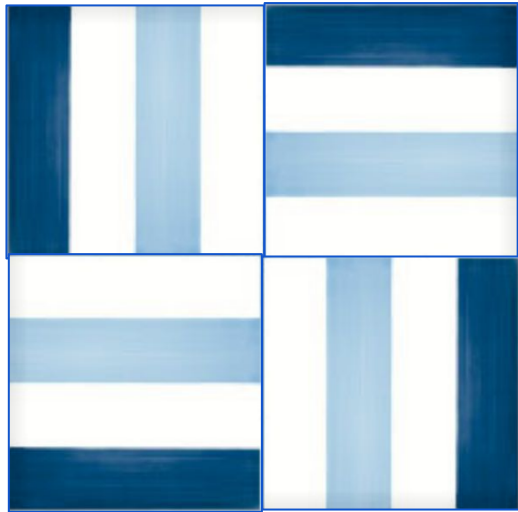

DAL DISEGNO ALLA MATTONELLA

DISEGNO 10

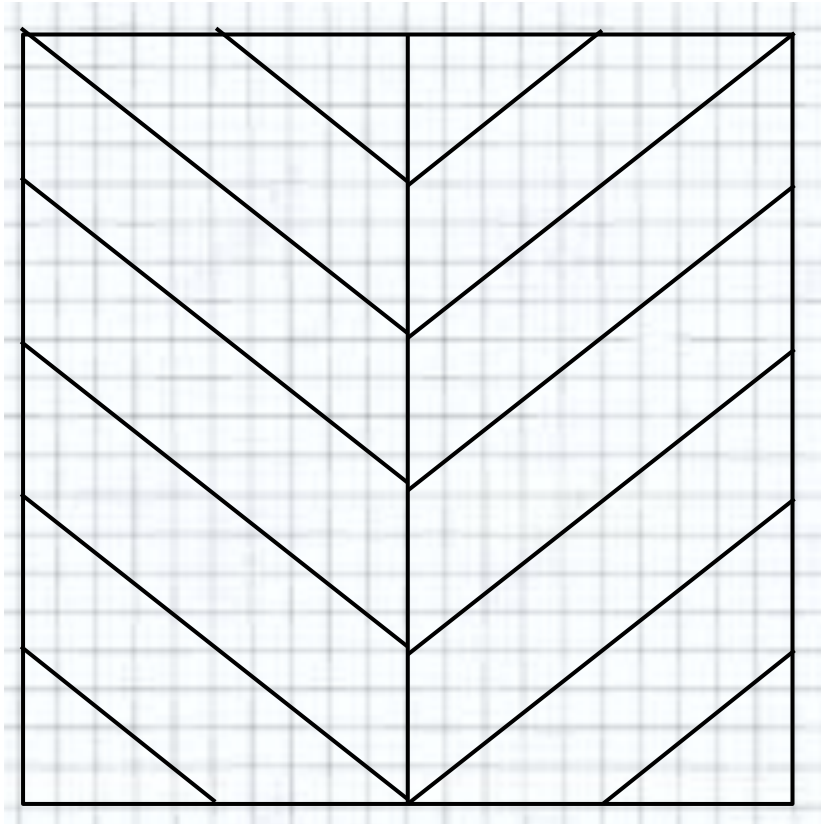

# COMPOSIZIONI

DISEGNO 10

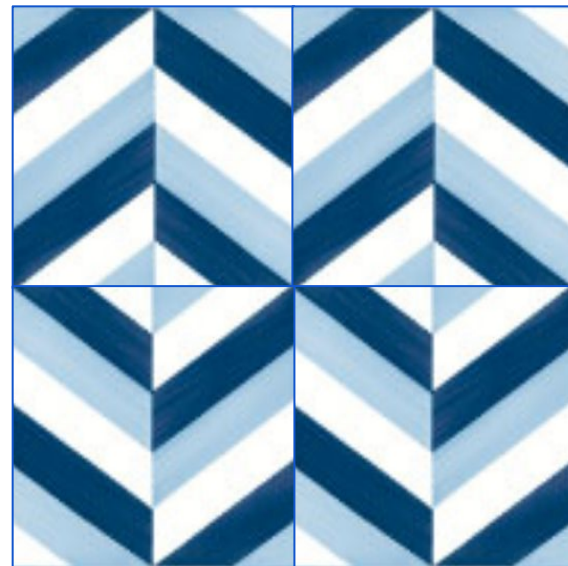
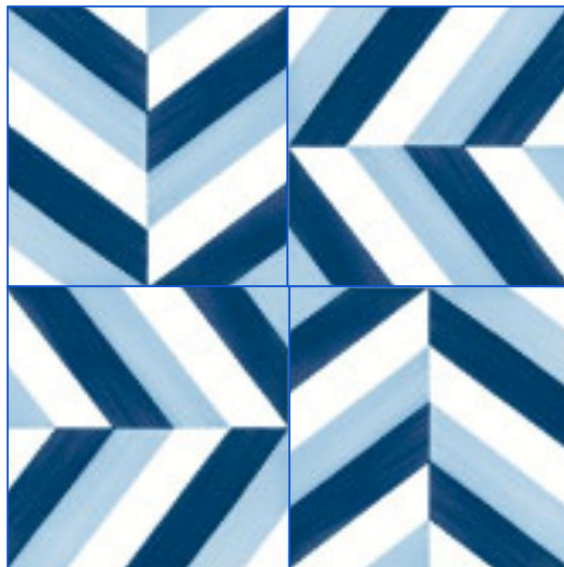
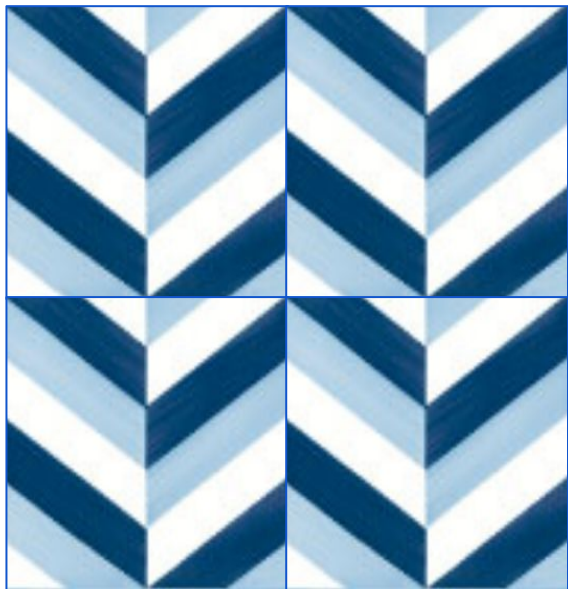



# DAL DISEGNO ALLA MATTONELLA

# DISEGNO 11

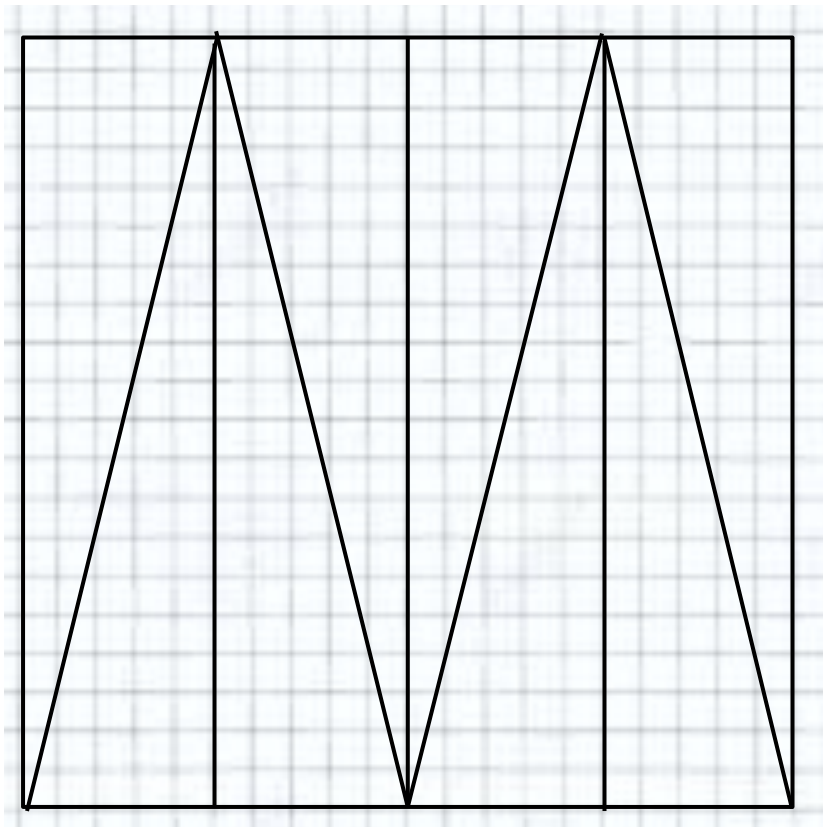

# COMPOSIZIONI

DISEGNO 11

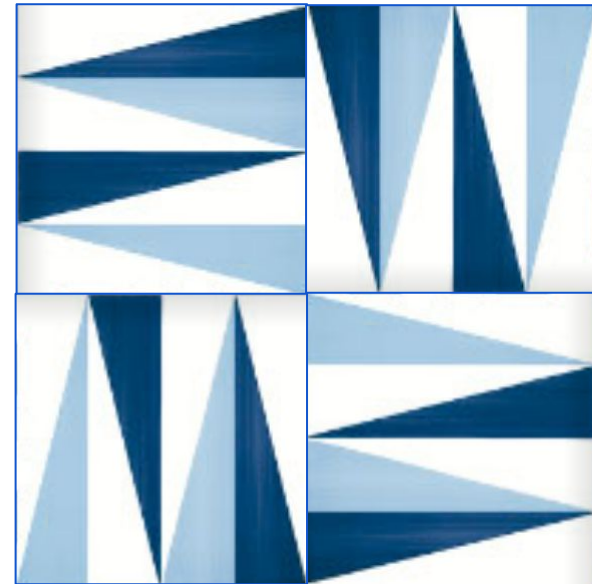
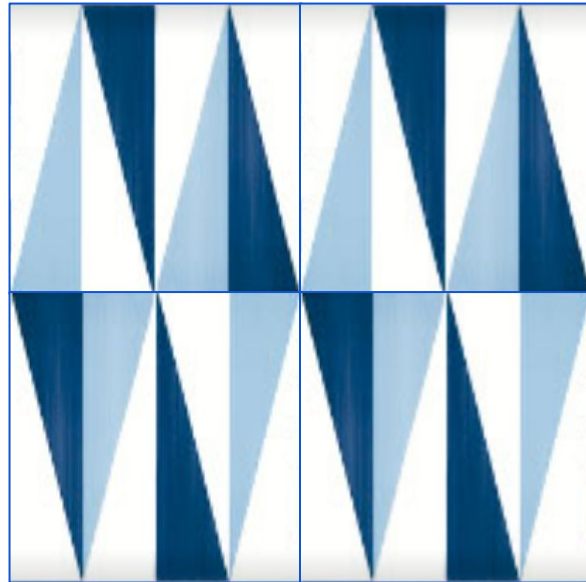
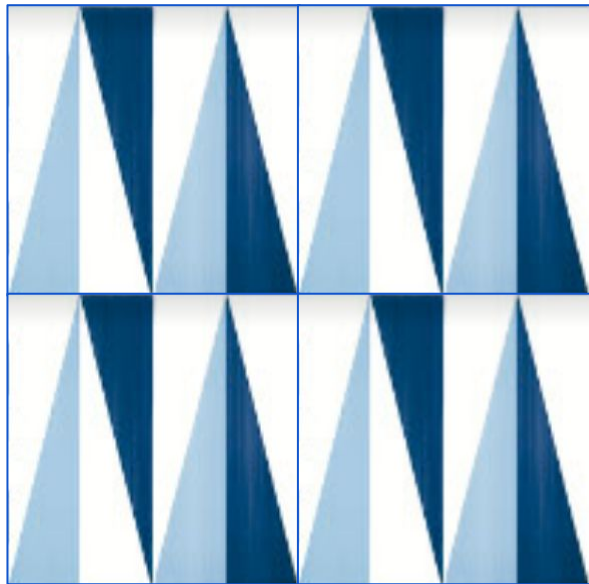

DAL DISEGNO ALLA MATTONELLA

DISEGNO 12

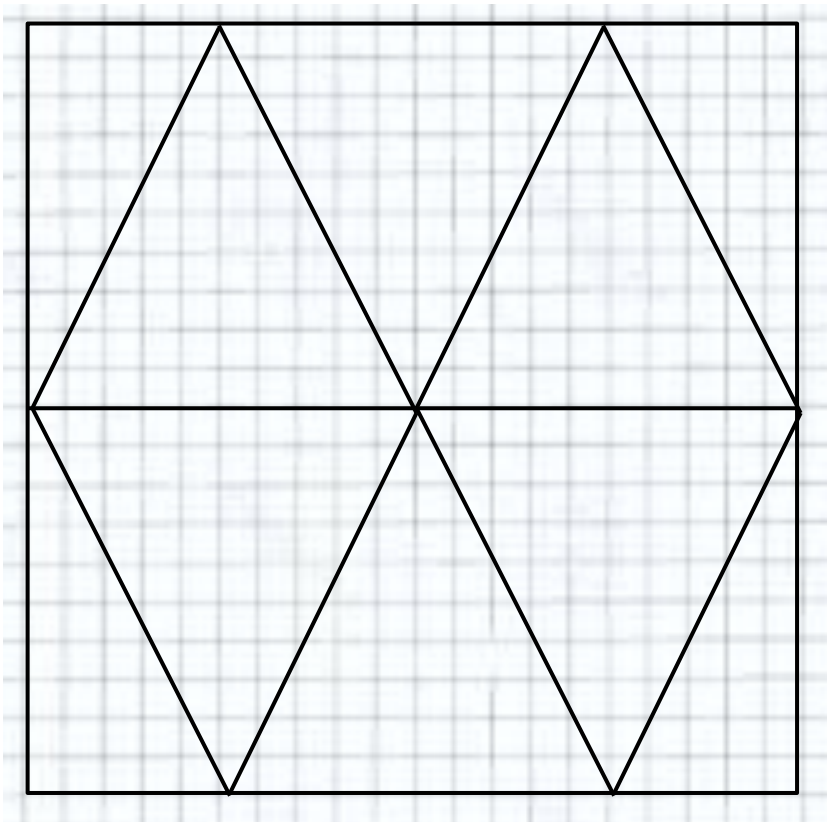

# COMPOSIZIONI

DISEGNO 12

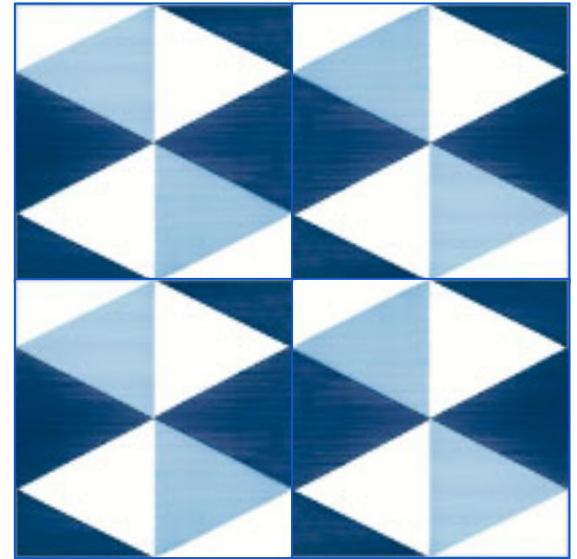
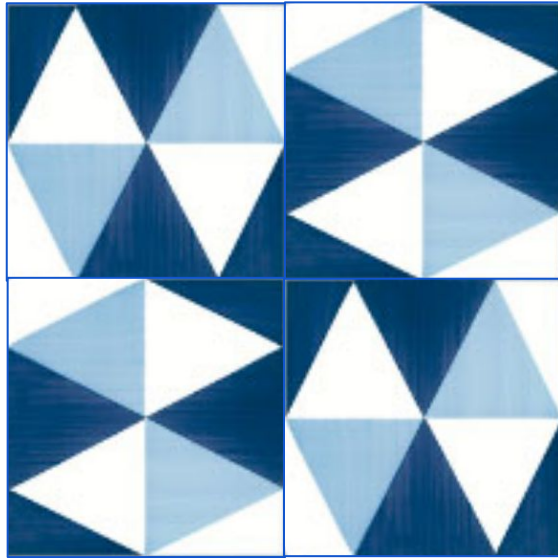
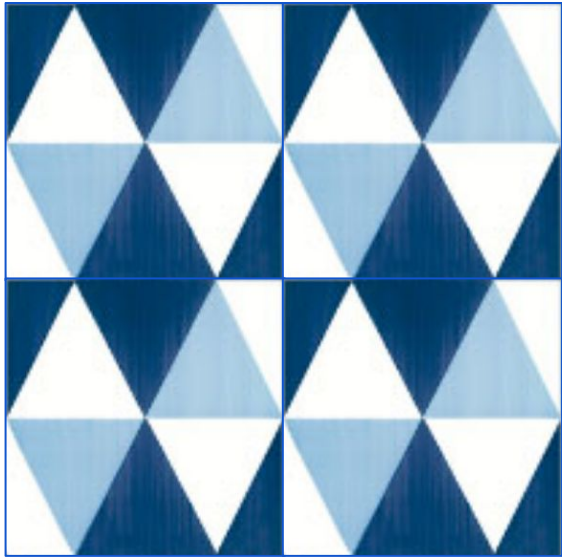

DAL DISEGNO ALLA MATTONELLA

DISEGNO 13

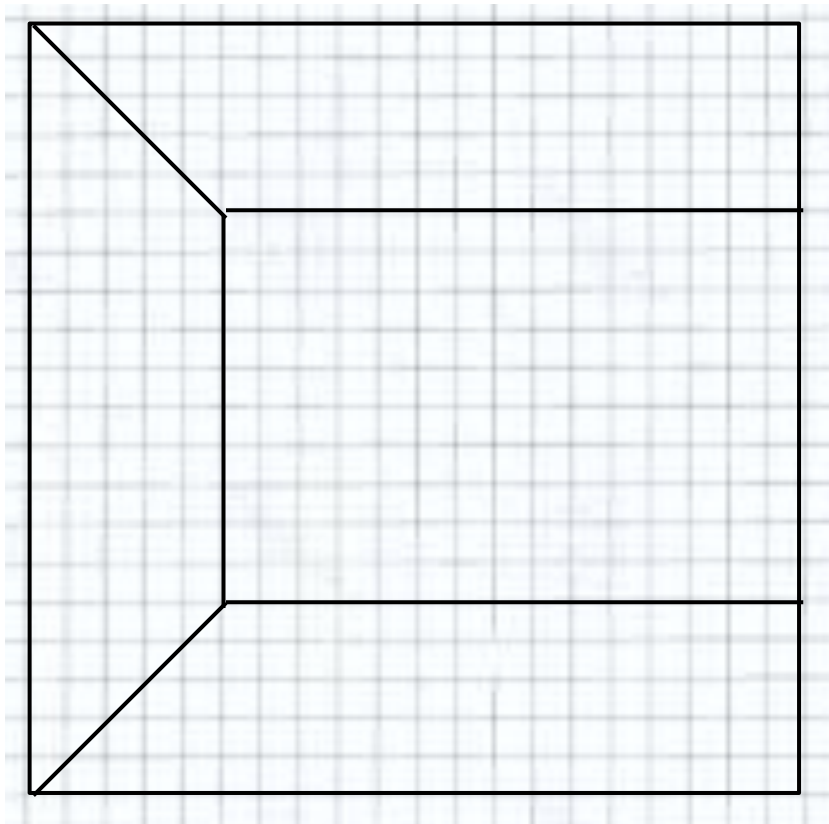



# COMPOSIZIONI

DISEGNO 13

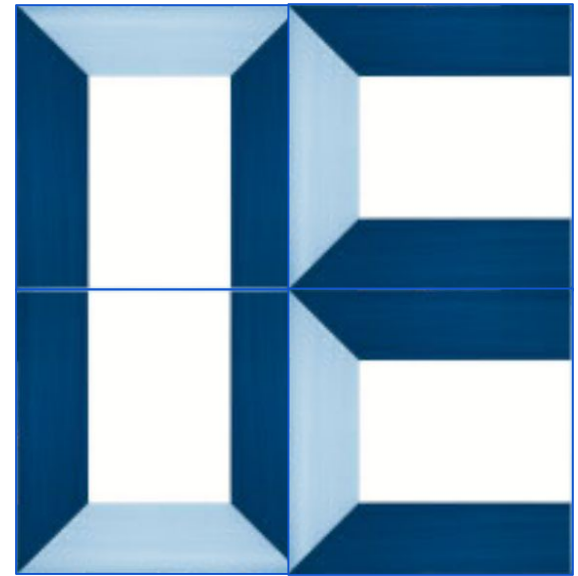
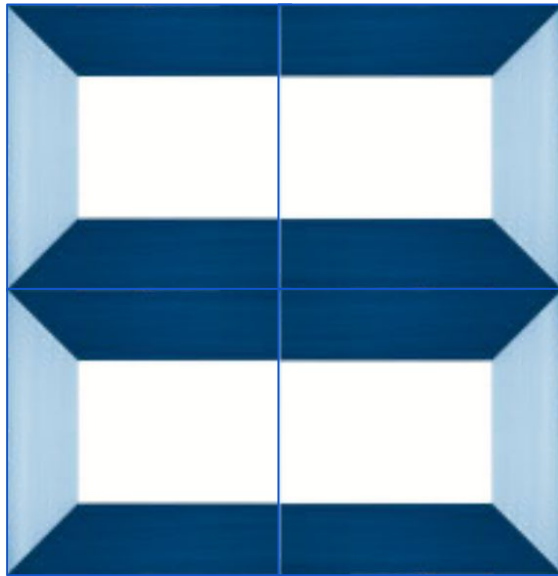

DAL DISEGNO ALLA MATTONELLA

DISEGNO 14

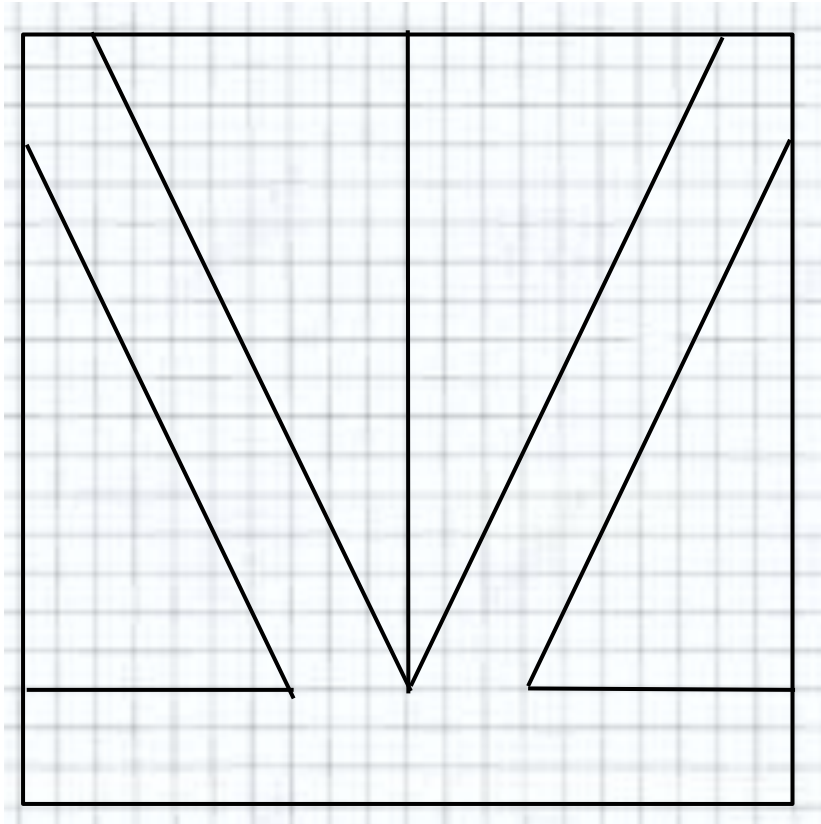

# COMPOSIZIONI

DISEGNO 14

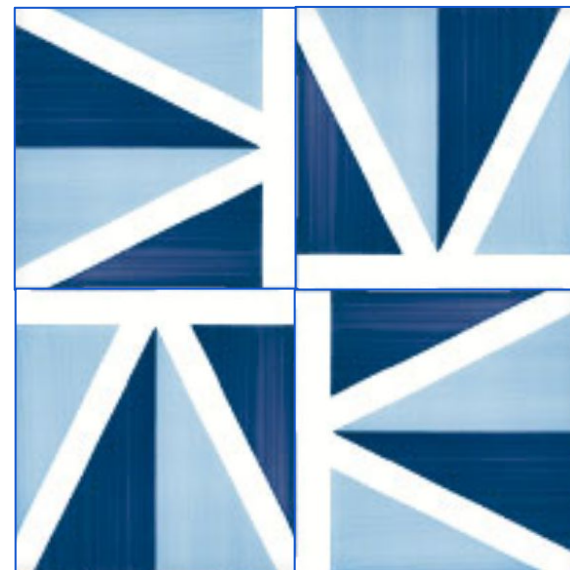
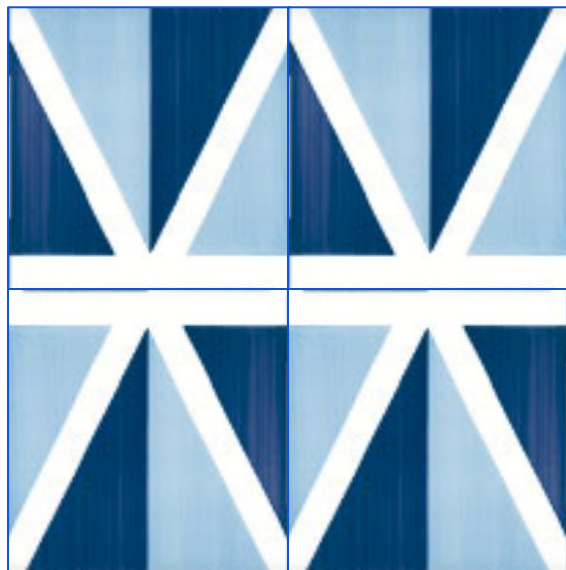
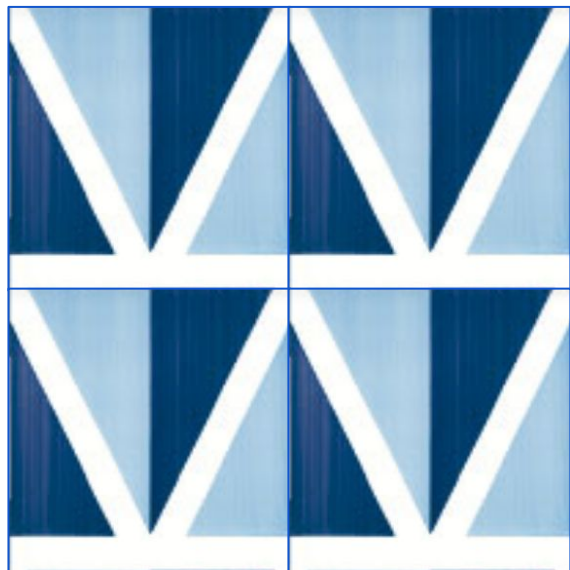

DAL DISEGNO ALLA MATTONELLA

DISEGNO 15

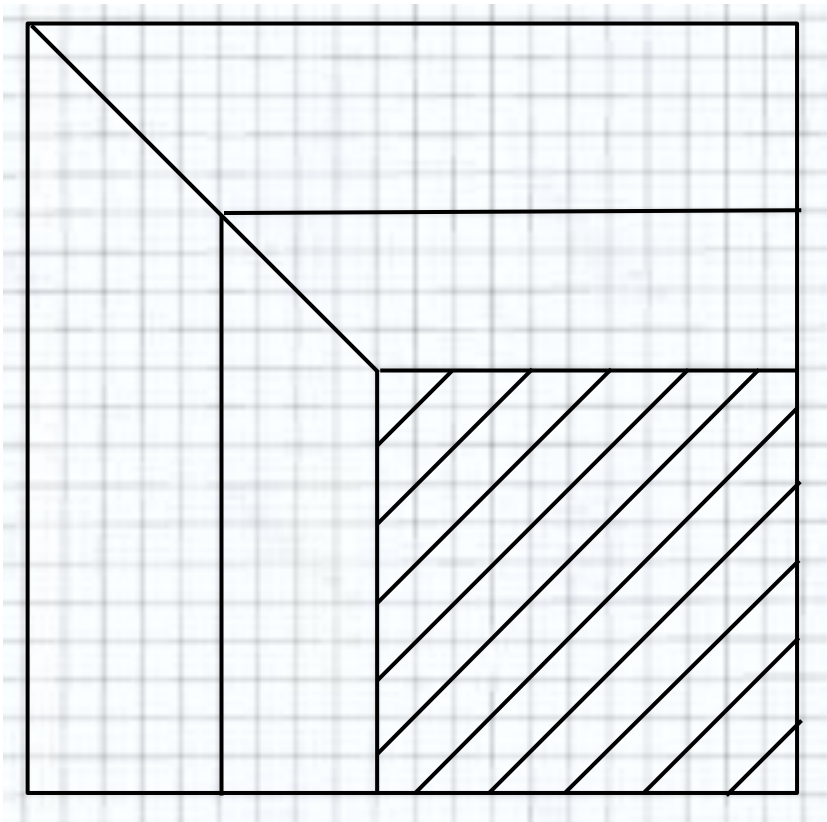

# COMPOSIZIONI

DISEGNO 15

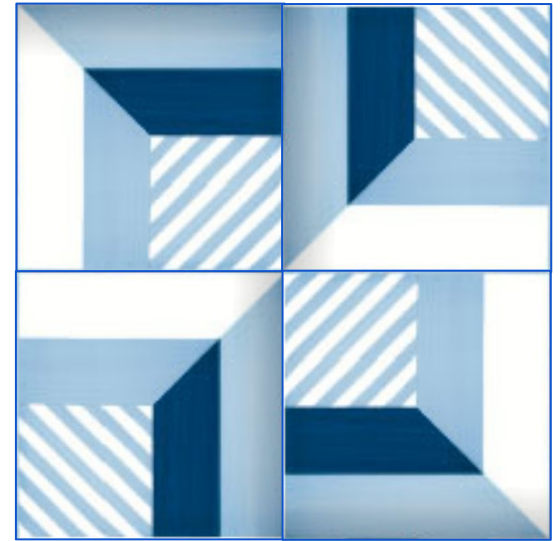
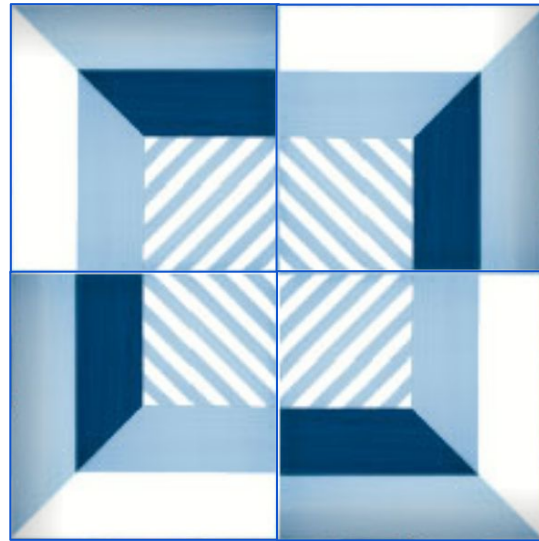
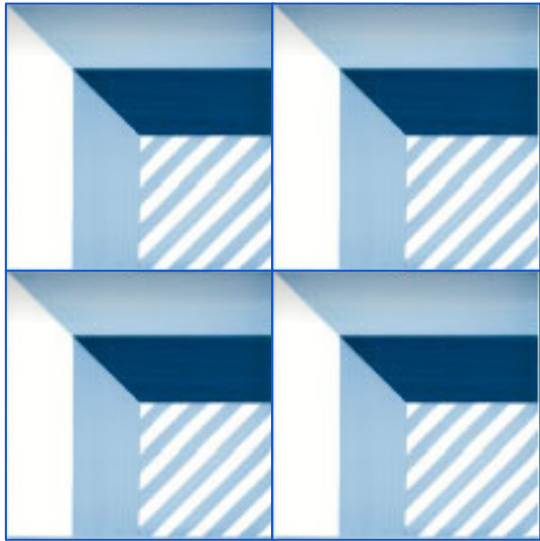



DAL DISEGNO ALLA MATTONELLA

DISEGNO 16

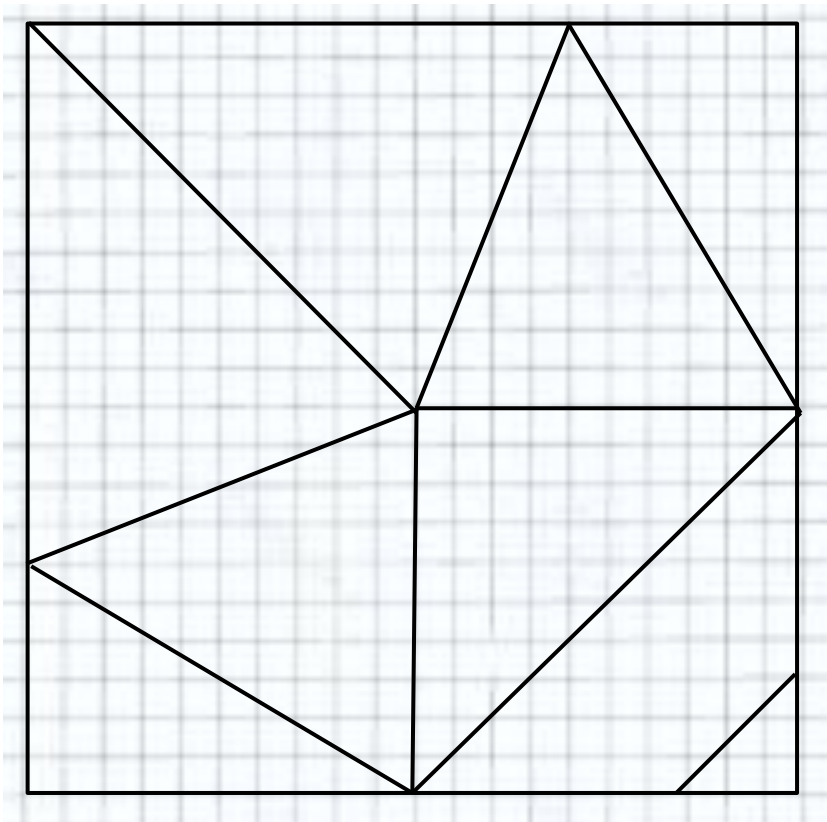

# COMPOSIZIONI

DISEGNO 16

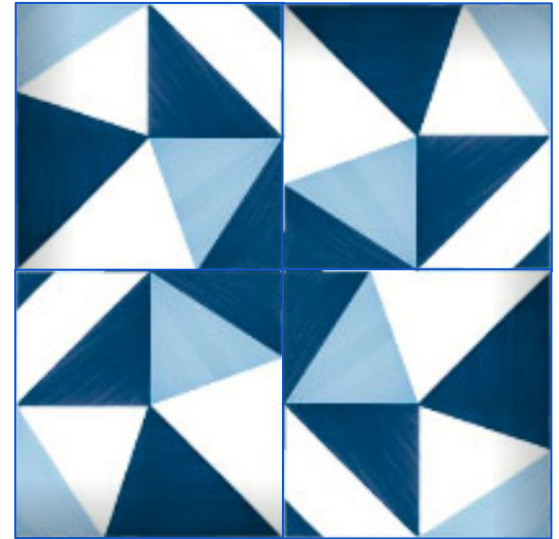
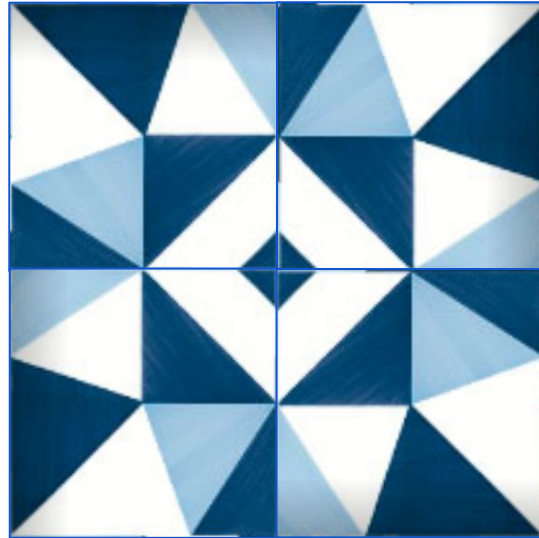
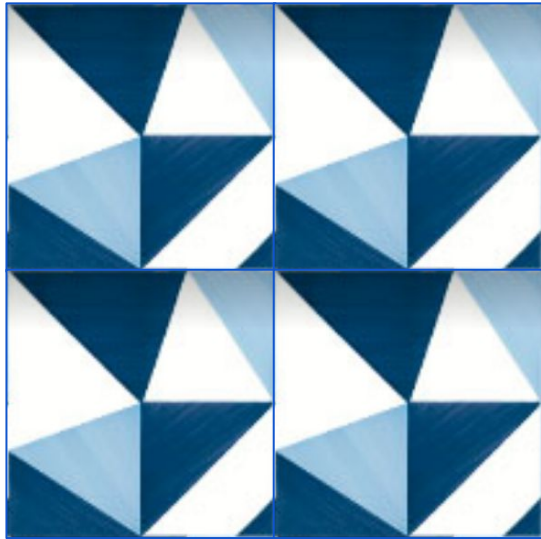

DAL DISEGNO ALLA MATTONELLA

DISEGNO 17

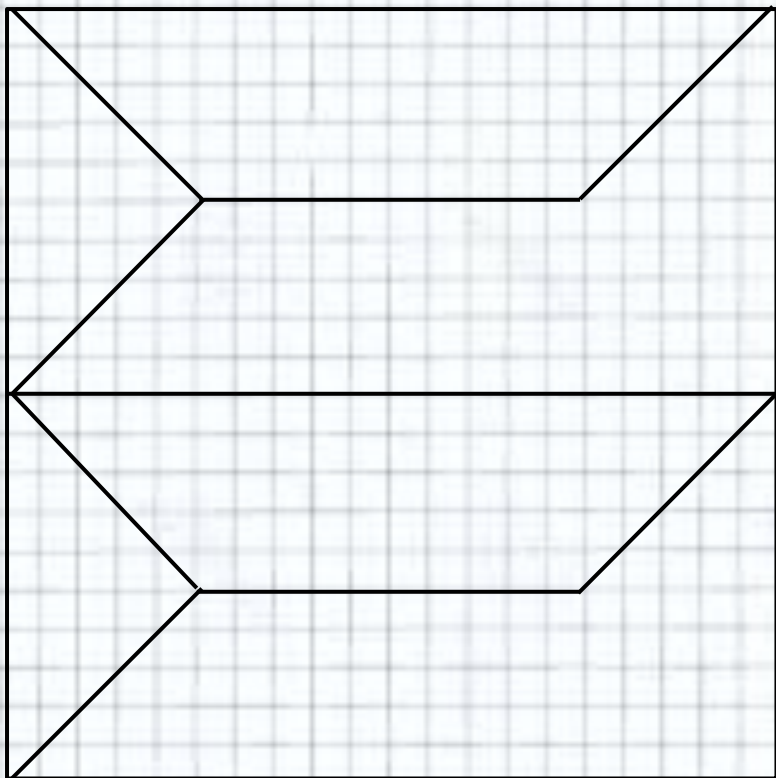

# COMPOSIZIONI

DISEGNO 17

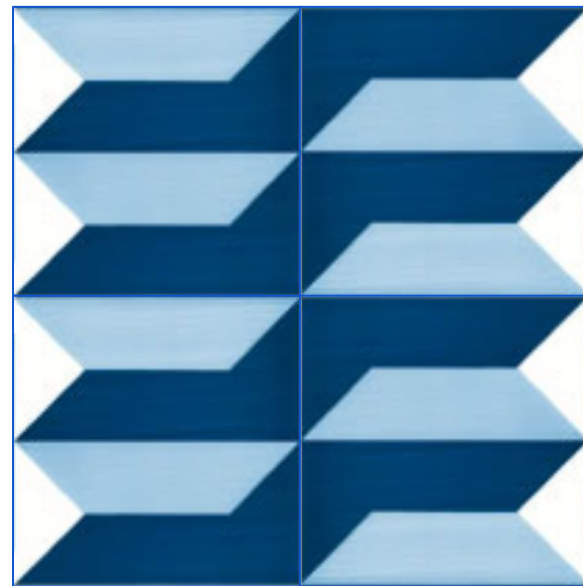
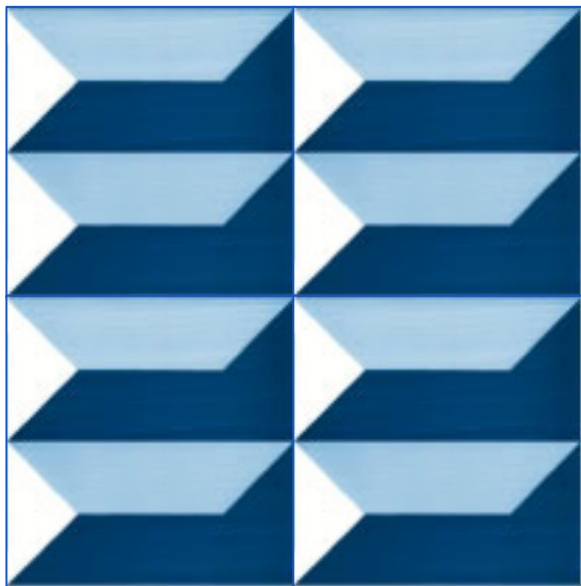

# DAL DISEGNO ALLA MATTONELLA

# DISEGNO 18

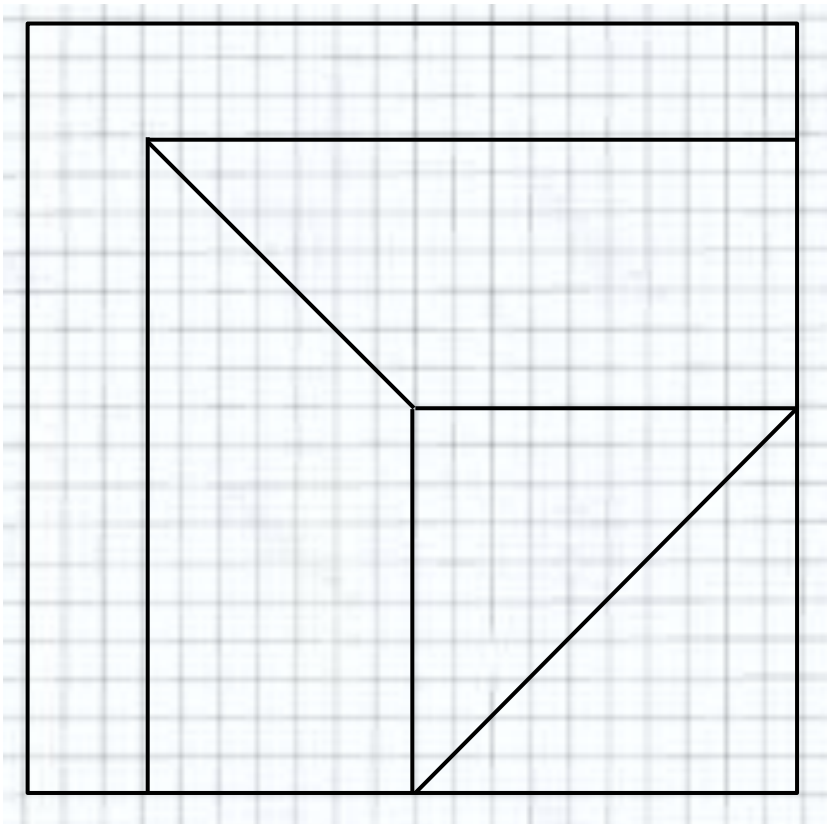



# COMPOSIZIONI

DISEGNO 18

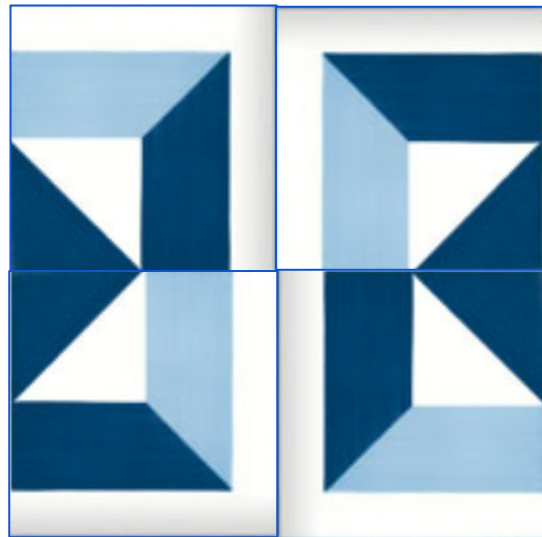
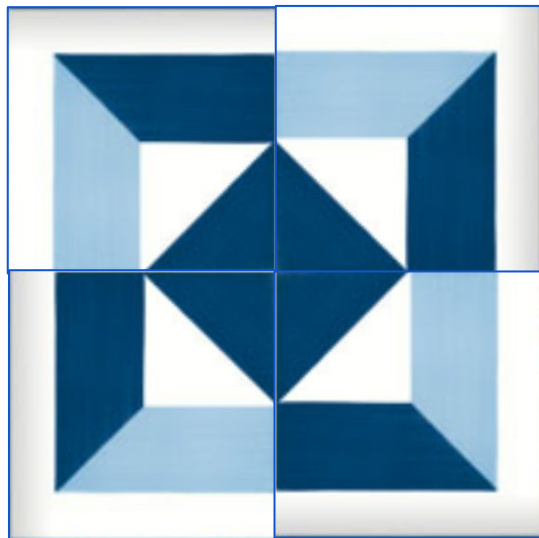
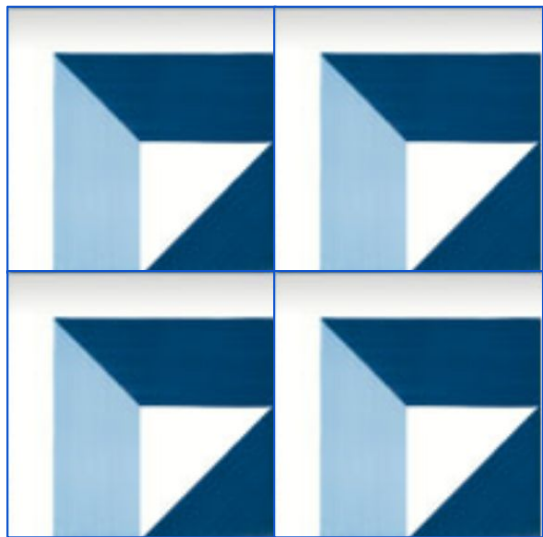

DAL DISEGNO ALLA MATTONELLA\

DISEGNO 19

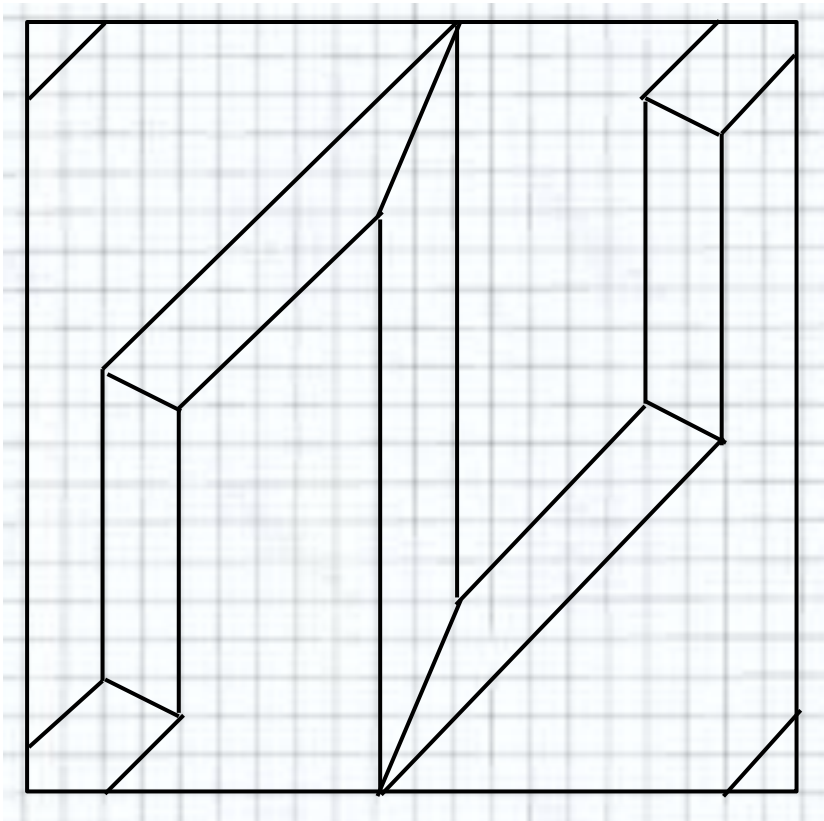

# COMPOSIZIONI

DISEGNO 19

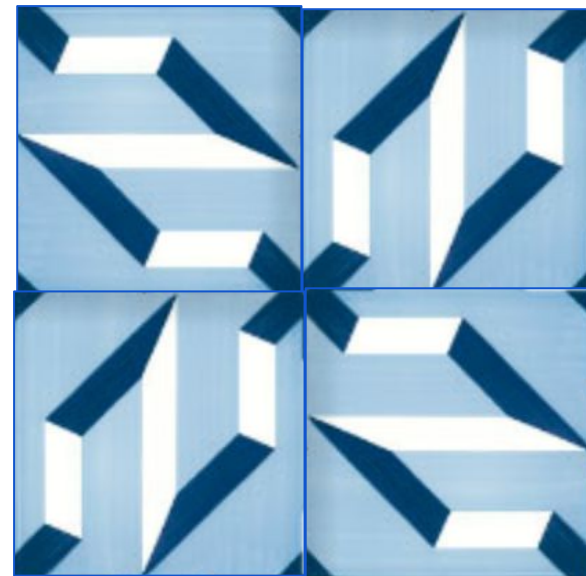
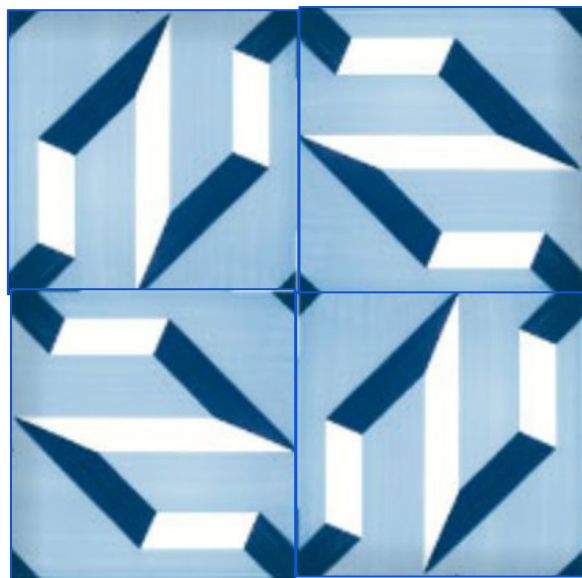
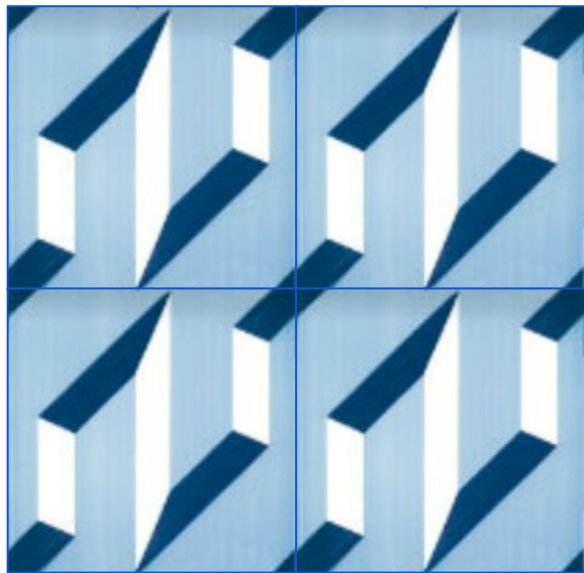

# LE COMBINAZIONI DEI COLORI

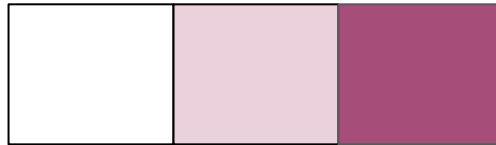

# E ORA REALIZZA LA TUA “MATTONELLA” - FASE 1

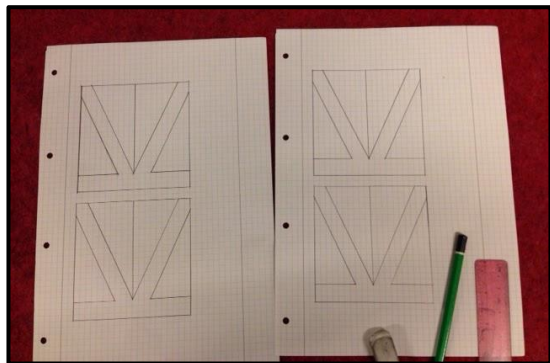

DOPO AVER SCELTO LA TUA GEOMETRIA PREFERITA, RIPRODUCILA PER QUATTRO VOLTE SUL FOGLIO A QUADRETTI (5mm); DIMENSIONI 20quad x 20quad (10cm x 10cm).  
UTILIZZA LA MATITA 2H, UN RIGHELLO O LA SQUADRETTA.

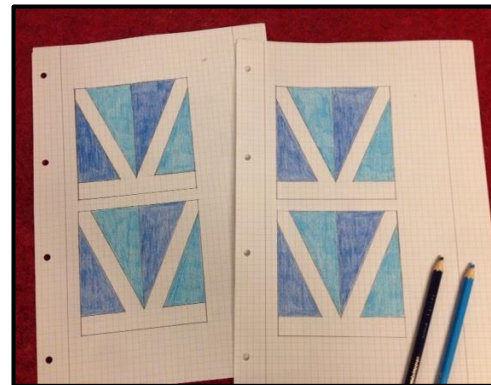

DOPO AVER SCELTO LA COMBINAZIONE DI COLORI, COLORA I QUATTRO QUADRATI E RITAGLIA CON PRECISIONE LUNGO I BORDI.

SCEGLI COME DISPORRE I QUATTRO QUADRATI TRA DIVERSE COMBINAZIONI POSSIBILI.



# E ORA REALIZZA LA TUA “MATTONELLA” - FASE 2



APPLICA SUL RETRO DEI QUADRATI ALCUNI PEZZETTI DI SCOTCH PER BLOCCARLI.

INSERISCI LA COMPOSIZIONE IN UN FOGLIO DI PLASTICA (RICORDATI DI LASCIARE UN PO' DI MARGINE) E PROCEDI ALLA PLASTIFICAZIONE.

ELIMINA LA PARTE DI PLASTICA IN ECCESSO.

INCOLLA CON LO SCOTCH BIOADESIVO IL FOGLIO PLASTIFICATO SU UN CARTONE DA IMBALLAGGIO (20cm x20cm).

SE VUOI APPENDERE LA TUA MATTONELLA AL MURO RICORDA DI APPLICARE PRIMA UN FERMAGLIO.

